

Freestanding Electric Pasta Cookers

The Elco 700HP range is comprised of over 100 models designed to guarantee the highest level of performance, reliability, energy saving, safety standards and ergonomic operation. These concepts are reflected in the total modularity of the range that ensures numerous configurations, either free-standing or bridged. Elco 700HP demonstrates how advanced technology can satisfy the needs of the professional caterer. The models detailed on this sheet are Freestanding Electric Pasta Cookers.



178745 + optional accessory 927221

EASY TO INSTALL

- Main connections can be accessed via the rear or base of the unit.

EASY TO CLEAN

- One piece pressed worktop in 1,5mm 304 AISI stainless steel with smooth, rounded corners.
- Front panel in 304 AISI stainless steel with Scotch Brite finish.
- All models have right-angled, laser cut side edges to allow flush-fitting joints between units eliminating gaps and possible dirt traps.
- Well in 316 AISI stainless steel guaranteeing high resistance against corrosion caused by water and salt.
- Recessed, double skinned door with pressed internal panel for

air-tight closure and better hygiene.

- Inside door panel in 304 AISI stainless steel.
- Feet in 304 AISI stainless steel adjustable up to 50mm in height.

EASY TO USE

- Easy to use control panel for power regulation and water tap.
- Skimming zone for collecting and discharging, through the overflow filter, of starches and foams.
- **Rapid System models:** control panel with switch to regulate rapid filling, boiling, boiling and refilling with pre-heated water.
- The electric pre-heating system built into the unit (on Rapid System models), guarantees rapid temperature recovery and a

production rate superior to standard models.

- Incoloy armoured heating elements positioned beneath the base of the well (on standard models).
- Skimming zone for collecting and discharging starches and foams, through the overflow filter.
- Safety Thermostat to avoid that the machine runs without water.
- Product 178754 provides 5 different cooking time programs per basket, providing more flexibility in the kitchen. In addition, 4 different boiling cycles may be chosen, varying from gentle, ideal from home made pasta, to full power for normal types of pasta.



Electrolux

Elco 700HP
Freestanding Electric Pasta Cookers

EASY TO MAINTAIN

- IPX4 water protection.
- Ease of maintenance guaranteed by frontal access to all working components.

EASY ON THE ENVIRONMENT

- 98% recyclable by weight.
- CFC free packaging.

*In accordance with CE regulations for gas models belonging to Class B11 (power over 14 kW), it is necessary to install a chimney (if installed under a hood) or chimney and draft diverter if the waste gases are vented directly outside.

	QCPE400 178745	QCPE800 178746	QCPE810 178747	QCPE820 178749	QCPE410 178754
TECHNICAL DATA					
Power supply	Electric	Electric	Electric	Electric	Electric
Water boiler			●	●	●
External dimensions - mm					
width	400	800	800	800	400
depth	730	730	730	730	730
height	850	850	850	850	850
height adjustment	50	50	50	50	50
N° of wells	1	2	1	1	1
Usable well dimensions - mm					
width	250	250	520	520	250
depth	400	400	300	300	400
height	300	300	260	260	300
Temperature limiter	●	●			
Well capacity - min/max - lt.	18, 24.5	18, 24.5	32, 40	32, 40	
Power - kW					
installed-electric	6	12	13	10	9
Net weight - kg.	50	50	70	70	55
Supply voltage	400 V, 3N, 50/60	400 V, 3N, 50/60	400 V, 3N, 50/60	400 V, 3N, 50/60	400 V, 3N, 50/60
Rapid System			●		●
INCLUDED ACCESSORIES					
4XSINGLE PORTION BASKETS				1	
LEFT SIDE DOOR FOR OPEN BASE CUPBOARD	1	1	1	1	
RIGHT SIDE DOOR FOR OPEN BASE CUPBOARD		1	1	1	
ACCESSORIES					
2 BASKETS 105X350 FOR PASTA COOKERS	921619	921619			921619
2 BASKETS 170X220 FOR PASTA COOKERS	921610	921610			921610
2 GN 1/2 BASKETS FOR PASTA COOKERS			927221	927221	
2 SIDE COVERING PANELS FOR TOP-D=700MM	216277	216277	216277	216277	
2 SIDE COVERING PANELS H=700 D=700	216000	216000	216000	216000	216000
2 SIDE KICKING STRIPS-CONCRETE INSTALL.	206265	206265	206265	206265	206265
3 GN 1/3 BASKETS FOR PASTA COOKERS			927214	927214	
3 ROUND BASKETS FOR PASTA COOKERS			927212	927212	
4 BASKETS 105X160 FOR PASTA COOKERS	921618	921618			921618
4 FEET FOR CONCRETE INSTALLATION	206210	206210	206210	206210	206210
4XSINGLE PORTION BASKETS			921698	921698	
6 ROUND BASKETS FOR PASTA COOKERS			927213	927213	
BASKET 350X220 FOR PASTA COOKERS	921611	921611			921611
CHIMNEY COVER 400MM OPEN	206284				
CHIMNEY COVER 800MM CLOSED			206271		
CHIMNEY COVER 800MM OPEN-LARGE CHIMNEY		206273	206273		
FALSE BOTTOM FOR 40L PASTA COOKER BASKET			206238	206238	
FLANGED FEET KIT	206136	206136	206136	206136	206136
FRONT.KICK.STRIP F.CONCRETE INST.1000 MM	206150	206150	206150	206150	206150
FRONT.KICK.STRIP F.CONCRETE INST.1200 MM	206151	206151	206151	206151	206151
FRONT.KICK.STRIP F.CONCRETE INST.1600 MM	206152	206152	206152	206152	206152
FRONT.KICK.STRIP F.CONCRETE INST.200 MM	206146	206146	206146	206146	206146
FRONT.KICK.STRIP F.CONCRETE INST.400 MM	206147	206147	206147	206147	206147
FRONT.KICK.STRIP F.CONCRETE INST.800 MM	206148	206148	206148	206148	206148
FRONTAL HANDRAIL 1200 MM	216049	216049	216049	216049	
FRONTAL HANDRAIL 1600 MM	216050	216050	216050	216050	
FRONTAL HANDRAIL 400 MM	216046	216046	216046	216046	
FRONTAL HANDRAIL 800 MM	216047	216047	216047	216047	
FRONTAL KICKING STRIP 1000 MM	206177	206177	206177	206177	206177
FRONTAL KICKING STRIP 1200 MM	206178	206178	206178	206178	206178
FRONTAL KICKING STRIP 1600 MM	206179	206179	206179	206179	206179
FRONTAL KICKING STRIP 200 MM	206174	206174	206174	206174	206174
FRONTAL KICKING STRIP 400 MM	206175	206175	206175	206175	206175
FRONTAL KICKING STRIP 800 MM	206176	206176	206176	206176	206176
GRID SUPPORT FOR ROUND BASKETS			927219	927219	
LARGE HANDRAIL(PORTIONING SHELF)400 MM	216185	216185	216185	216185	
LARGE HANDRAIL(PORTIONING SHELF)800 MM	216186	216186	216186	216186	
LEFT SIDE DOOR FOR OPEN BASE CUPBOARD				216195	
LID FOR 40LT PASTA COOKER 700 LINE			927218	927218	
LID FOR PASTA COOKERS	921607	921607		921607	921607
PAIR OF SIDE KICKING STRIPS	206249	206249	206249	206249	206249
RIGHT AND LEFT SIDE HANDRAILS	206240	206240	206240	206240	206240
RIGHT SIDE DOOR FOR OPEN BASE CUPBOARD				216194	
SUPPORT FOR 4 PASTA COOKER BASKETS	921606	921606			921606

CGGB010

2008-04-04

Subject to change without notice

Elco 700HP
Freestanding Electric Pasta Cookers

178745

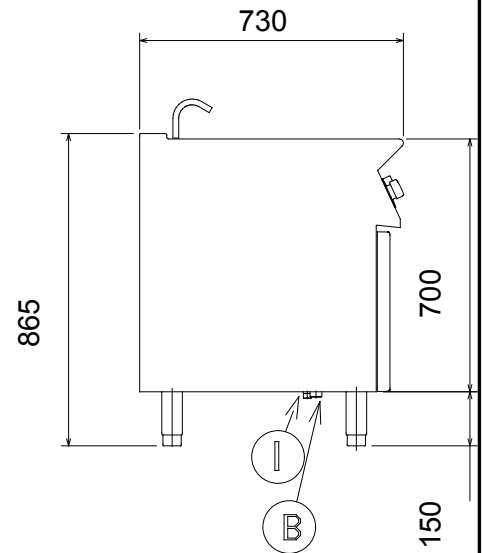
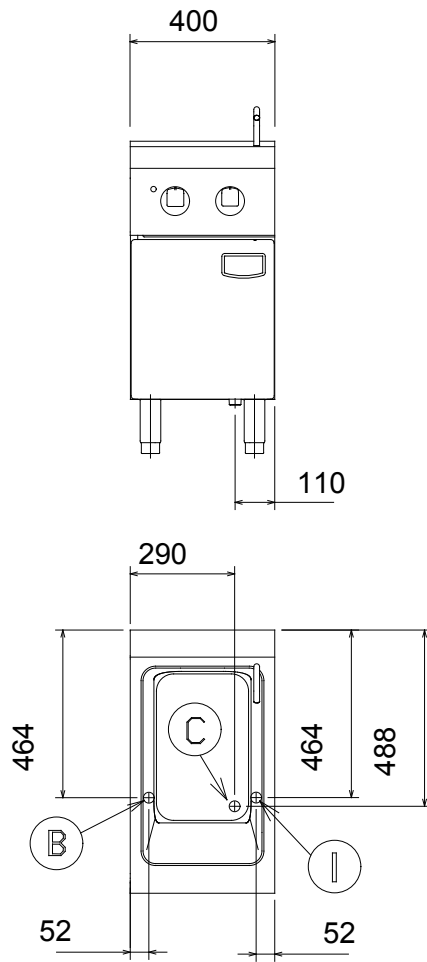

597842500

CGGB010

2008-04-04

LEGEND B - Cold water inlet C - Water drain I - Electrical connection	QCPE400 178745
	1/2"
	1"
	400 V, 3N, 50/60

Subject to change without notice

Elco 700HP
Freestanding Electric Pasta Cookers

178746

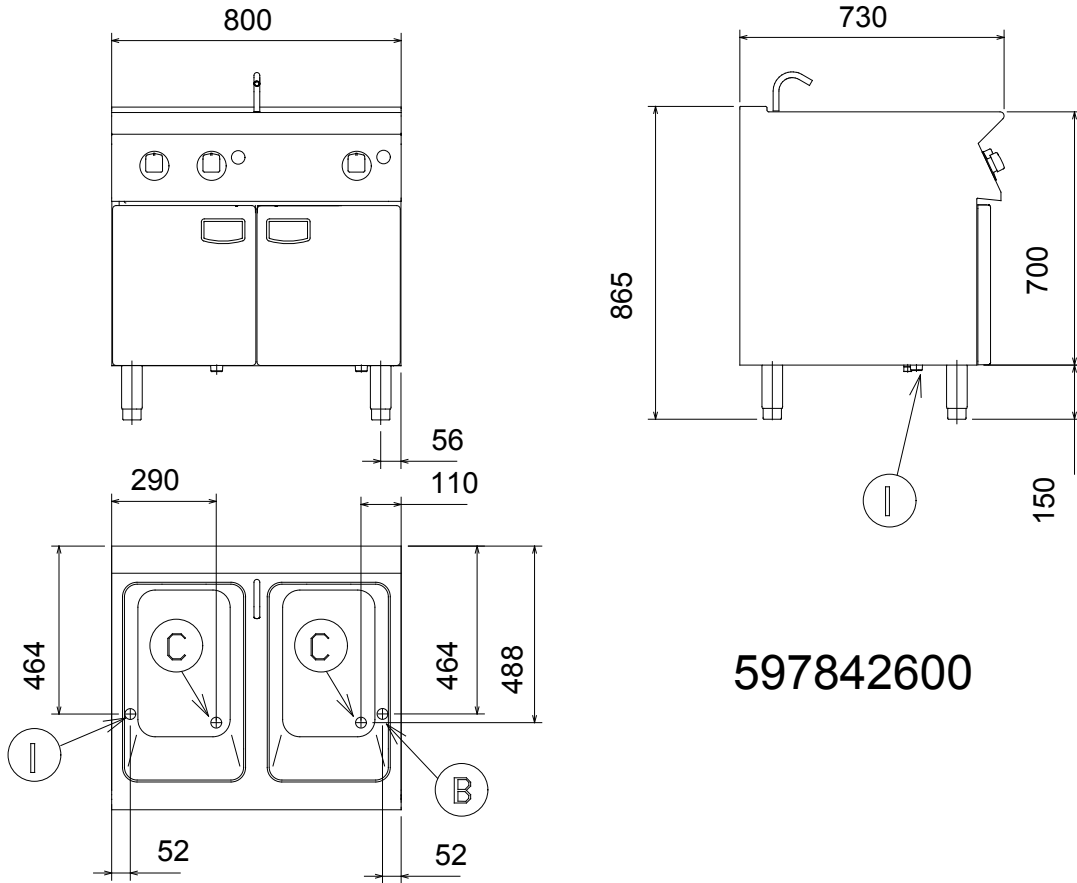

597842600

CGGB010

2008-04-04

LEGEND B - Cold water inlet C - Water drain I - Electrical connection	QCPE800 178746
	1/2"
	1"
	400 V, 3N, 50/60

Subject to change without notice

Elco 700HP
Freestanding Electric Pasta Cookers

178747

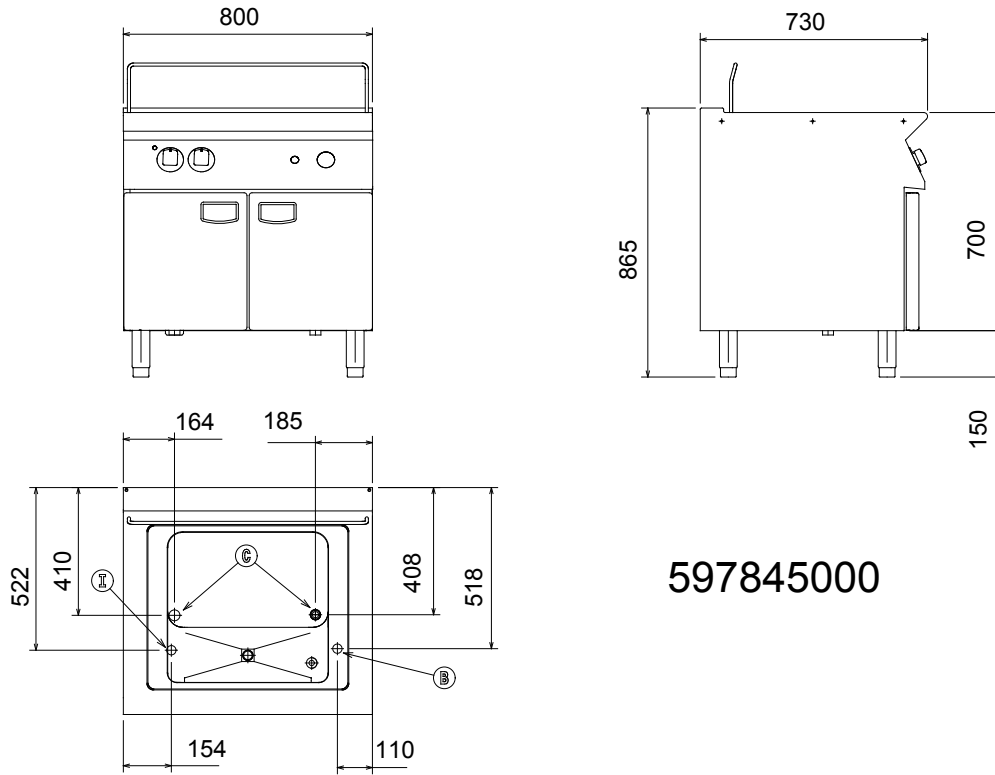

597845000

LEGEND B - Cold water inlet C - Water drain I - Electrical connection	QCPE810 178747
	1/2"
	1"
	400 V, 3N, 50/60

CGGB010

2008-04-04

Subject to change without notice

**Elco 700HP
Freestanding Electric Pasta Cookers**

178749

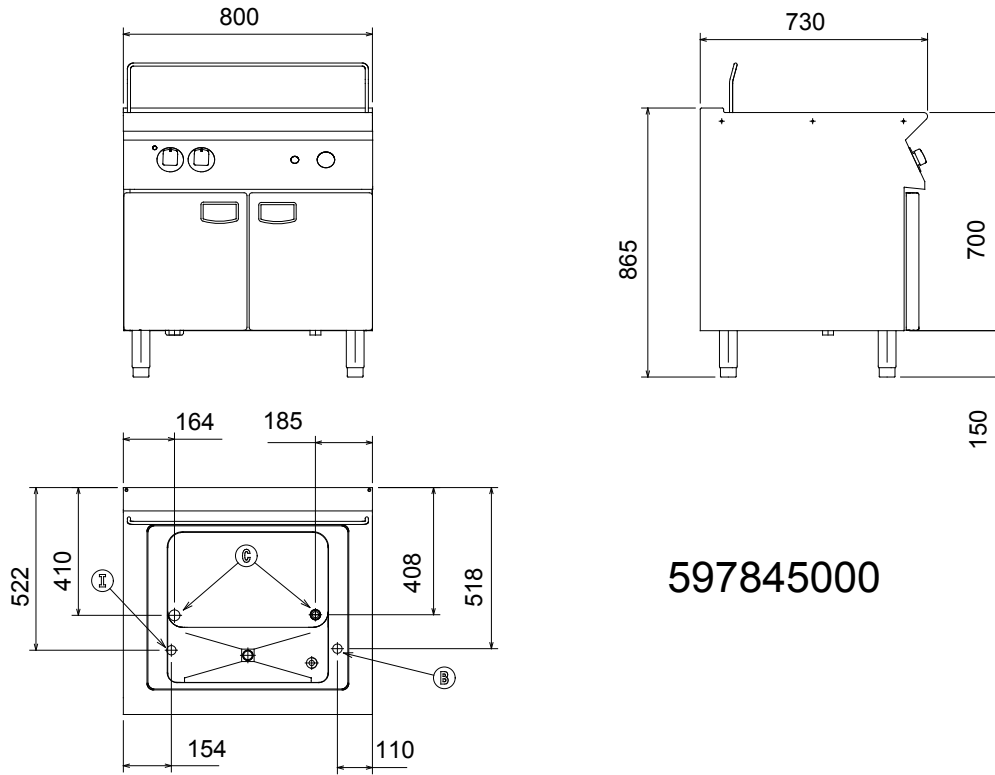

597845000

LEGEND B - Cold water inlet C - Water drain I - Electrical connection	QCPE820 178749
	1/2"
	1"
	400 V, 3N, 50/60

CGGB010

2008-04-04

Subject to change without notice

Elco 700HP
Freestanding Electric Pasta Cookers

178754

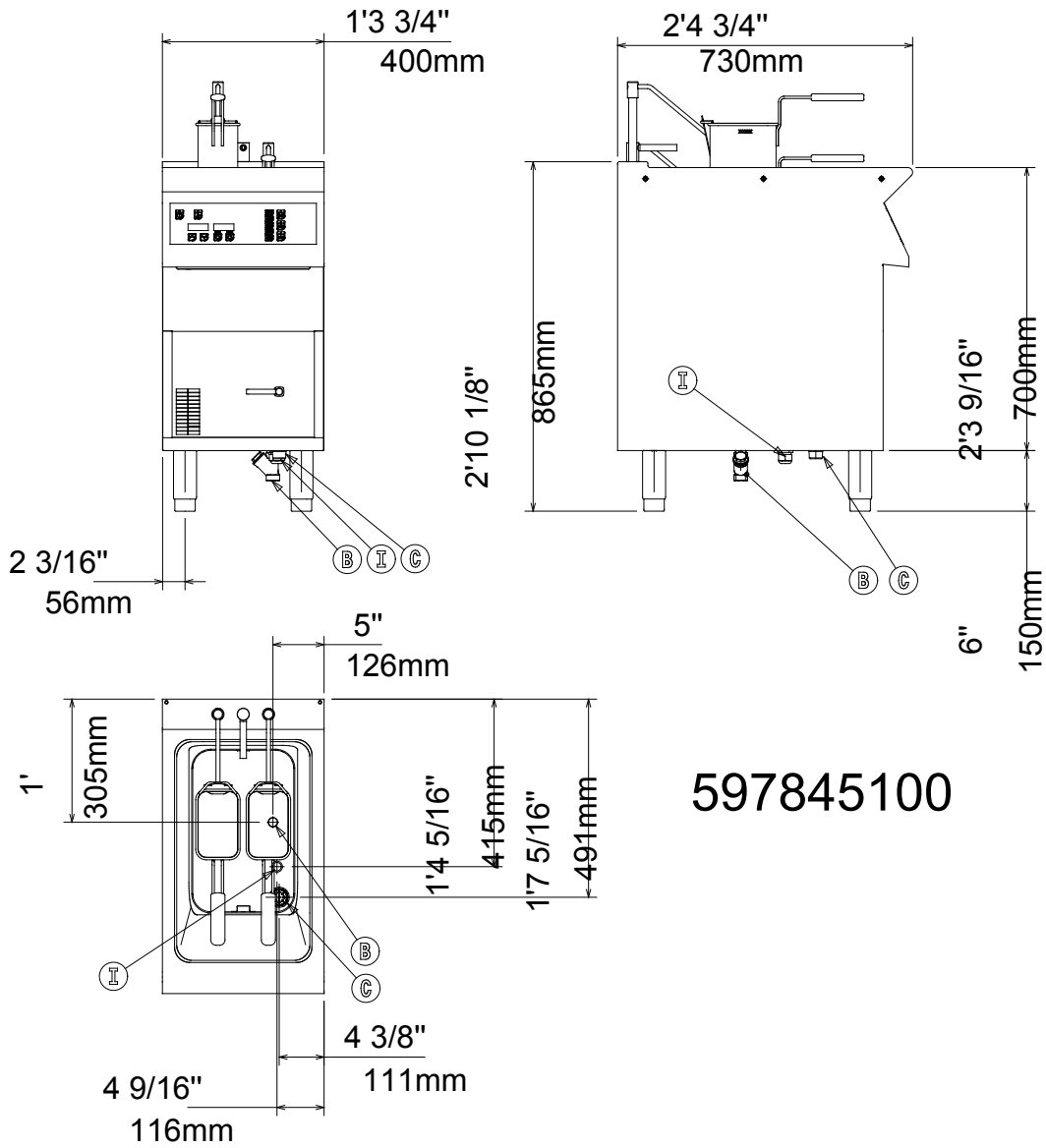

597845100

LEGEND B - Cold water inlet C - Water drain I - Electrical connection	QCPE410 178754
	3/4"
	1"
	400 V, 3N, 50/60

CGGB010

2008-04-04

Subject to change without notice