

Electrolux Dishwashing

Glasswashers WT2

The Electrolux Dishwashing range is produced for customers with the highest conceivable demands for good efficiency, economy and ergonomics for dishwashing operation. The product range comprises glasswashers, undercounter dishwashers, hood type dishwashers, rack type dishwashers, flight type dishwashers and pot and pan washers. The glasswasher range consists of models with different charging holes, in order to handle glasses up to 210 mm or 290 mm height, that are equipped with or without drain pump, with or without water softner and with or without detergent dispenser.



Model 402035

EASY TO INSTALL AND MAINTAIN

- The glasswashers can be supplied with 1 phase 230V or 3 phase 400V.
- Models are equipped with a drain pump to facilitate the installation.
- Rinse booster pump available to be installed on site.
- Simple service from the front.

EASY TO CLEAN

- The glasswashers have smooth surfaces and a fully pressed wash tank with rounded corners to facilitate cleaning.
- All the internal elements (arms and filter) are easily extractable.
- 304 AISI stainless steel front and side panels, wash tank, tank filter and wash and rinse arms.

EASY TO USE

- Built-in rinse water heater to increase the temperature of the final rinse water.
- Built-in rinse aid dispenser for perfect rinsing results.
- Simple control panel.
- One dishwashing program for normally soiled items.
- An extra program for cold rinsing of beer glasses.

CONSTRUCTION FEATURES

- Double skinned construction.
- Wash/rinse arms and nozzles in stainless steel.
- Completely closed on the reverse by a cover plate.
- All models finished in top quality materials to aid durability.
- Built-in water softener.

EASY ON THE ENVIRONMENT

- 98% recyclable by weight.
- CFC free packaging.
- Low noise level.
- Developed and produced in ISO 9001 and ISO 14001 certified factory.



Electrolux

**Electrolux Dishwashing
Glasswashers WT2**

	WT2N 402035	WT2 402030	WT2TOP 402044	WT2WSDPD 402032	WT2N4 402047
TECHNICAL DATA					
Water supply					
pressure min. , max. - bar	2, 3	2, 3	2, 3	2, 3	2, 3
temperature - °C	10	10	10	10	10
hardness - °f	>14	>14	>14	>14	7-14
hardness - °d	>8	>8	>8	>8	4-8
Cold rinse	●	●	●	●	●
Water softener	●	●	●	●	
Drain pump		●	●	●	●
Rinse Booster Pump			●		
Detergent dispenser				●	
N° of cycles	2	2	2	2	2
Basket capacity/h	30	30	30	30	30
External dimensions - mm					
width	460	460	460	460	460
depth	565	565	565	565	565
height	715	715	715	715	715
Duration cycles - sec.	120/300	120/300	120/300	120/300	120/300
Cell dimensions - mm					
width	400	400	400	400	400
depth	400	400	400	400	400
height	290	290	290	290	290
Washing cycle					
temperature -°C	55-65	55-65	55-65	55-65	55-65
tank capacity - lt.	6	6	6	6	6
power pump - kW	0.3	0.3	0.3	0.3	0.3
electrical elements - kW	0.8	0.8	0.8	0.8	0.8
Cold rinse cycle					
duration - sec.	10	10	10	10	10
temperature - °C	10	10	10	10	10
water consumption - lt./cycle	2	2	2	2	2
Hot rinse cycle					
duration - sec.	16	16	16	16	16
temperature during rinse - °C	80-90	80-90	80-90	80-90	80-90
water consumption - lt./cycle	2.3	2.3	2.3	2.3	2.3
Boiler capacity - lt.	5	5	5	5	5
Boiler elements - kW	3	3	3	3	4.5
Power - kW					
drain pump		0.034	0.034	0.034	0.034
total power	3.3	3.3	3.3	3.3	4.8
Net weight - kg.	37	37	37	37	37
INCLUDED ACCESSORIES					
BASKET FOR GLASSES-395X395X100 MM			2		
BASKET FOR GLASSES-395X395X200 MM	1	1		1	1
CUTLERY HOLDER			1		
INSERT FOR 14 SAUCERS			1		
ACCESSORIES					
BASKET F.GLASSES-ANGLED BASE-395X395X200	867056	867056	867056	867056	867056
BASKET FOR 16/8 PLATES DIAM.190/240 MM	867052	867052	867052	867052	867052
BASKET FOR GLASSES+SAUCERS/CUTLERY INS.	867055	867055	867055	867055	867055
BASKET FOR GLASSES-395X395X200 MM	867054	867054	867054	867054	867054
COVER GRID FOR SMALL/LIGHT ITEMS IN RACK	867016	867016	867016	867016	867016
CUTLERY HOLDER	867059	867059		867059	867059
FILTER FOR PARTIAL DEMINERALIZATION			864017		864017
FILTER FOR TOTAL DEMINERALIZATION			864015		864015
INCLINED INSERT FOR CUPS	867061	867061	867061	867061	867061
INSERT FOR 14 SAUCERS	867060	867060		867060	867060
INSERT FOR 7 PLATES DIAM. 240 MM	867062	867062	867062	867062	867062
INSERT FOR"FLUTE"GLASSES	867058	867058	867058	867058	867058
KIT OF 4 SQUARE CUTLERY HOLDERS			867018		
KIT TO MEASURE TOTAL/PART.WATER HARDNESS	864050	864050	864050	864050	864050
RINSE BOOSTER PUMP KIT	867063	867063		867063	867063
ROUND BASKET KIT WITH SQUARE FRAME	867057	867057	867057	867057	867057

IAB010

2008-04-03

Subject to change without notice

**Electrolux Dishwashing
Glasswashers WT2**

402035

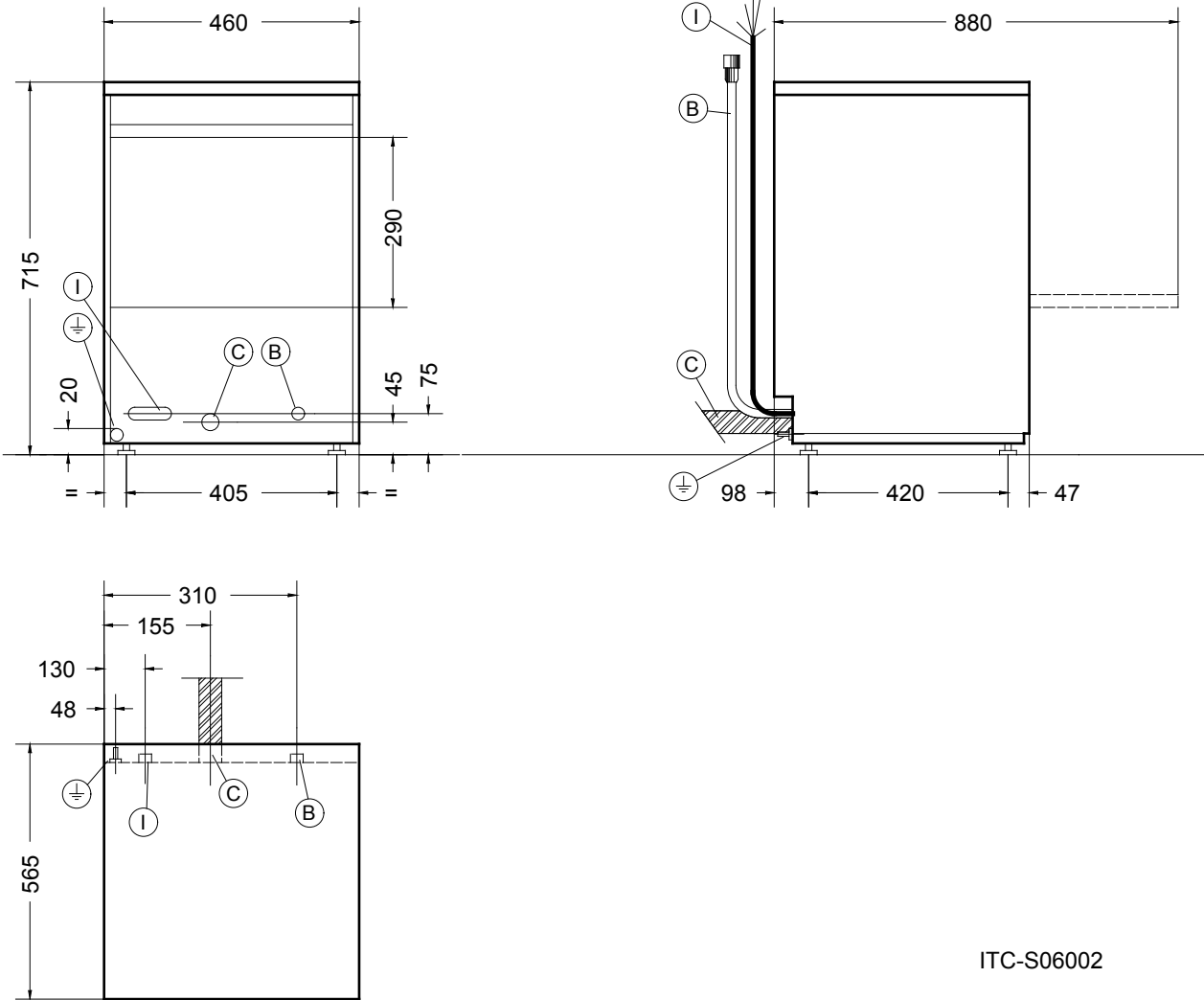

ITC-S06002

IAB010

2008-04-03

LEGEND	B - Cold water inlet	WT2N 402035
	C - Water drain	G 3/4"
	I - Electrical connection	22mm
		230 V, 1N, 50

Subject to change without notice

**Electrolux Dishwashing
Glasswashers WT2**

402030, 402047, 402032, 402044

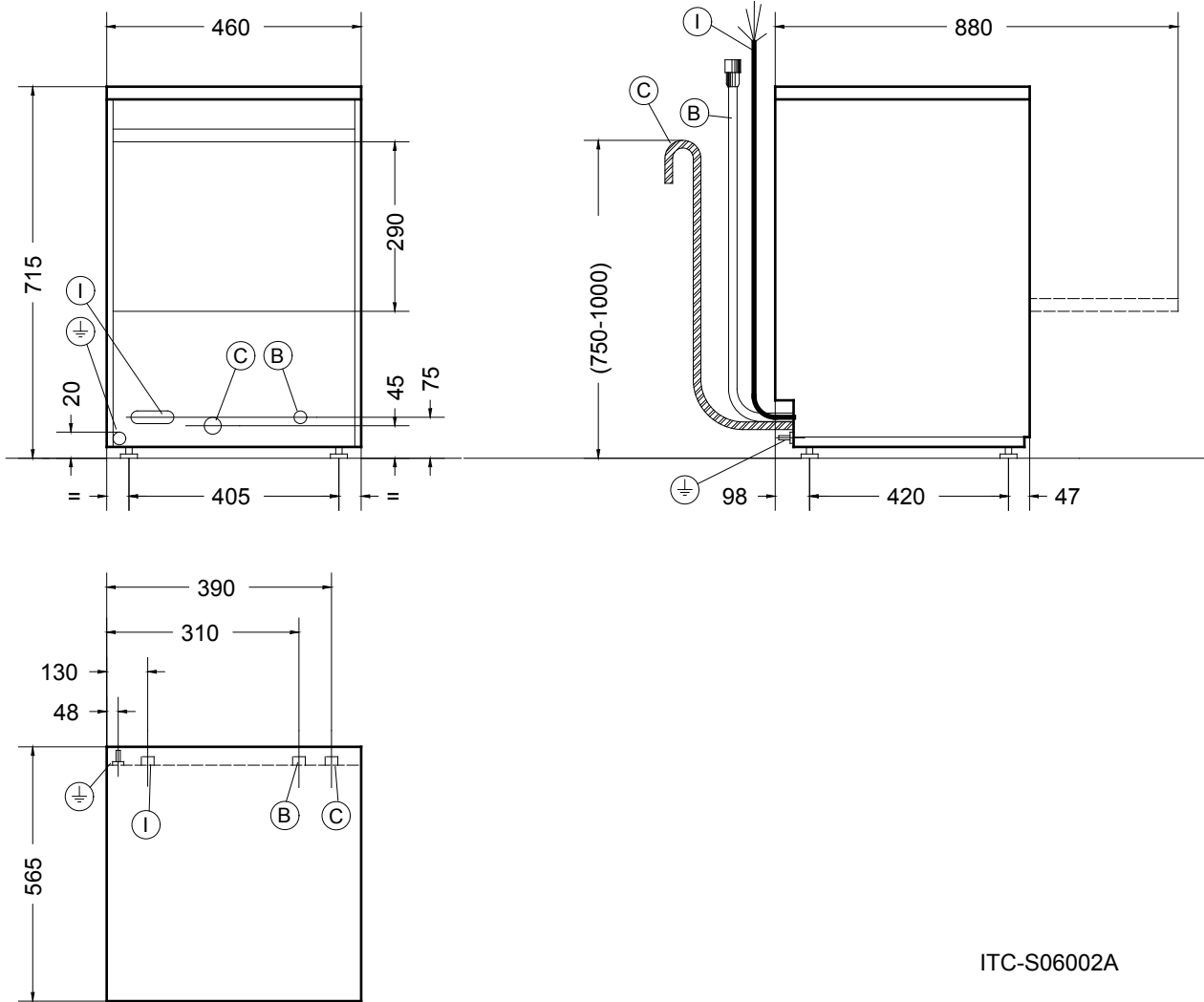

IAB010

2008-04-03

	WT2 402030	WT2TOP 402044	WT2WSDPD 402032	WT2N4 402047
LEGEND				
B - Cold water inlet	G 3/4"	G 3/4"	G 3/4"	G 3/4"
C - Water drain	27mm	27mm	27mm	27mm
I - Electrical connection	230 V, 1N, 50	230 V, 1N, 50	230 V, 1N, 50	400 V, 3N, 50

Subject to change without notice