

## Cashier Units

The Electrolux Self Service has been developed from our extensive experience in designing commercial kitchens and self service solutions all over the world. It allows the professional caterer to create a self service area that offers the right functions and the required capacity, efficiently organising the flow of customers and service, while blending in with the rest of the furnishing. The cashier units come with protective panelling.



330127

- 20/10 top, external panelling and base in 304 AISI stainless steel.
- Adjustable stainless steel feet (up to 200 mm).
- The units are equipped with a small drawer with key and shuko plug for electric connection.
- Models ZLCL12R and ZLCL12L are "L" shaped right and left side respectively.
- All models comply with the standards required by the main international approval bodies and are CE marked.
- All models are NF\* certified.

\*NF HYGIENE ALIMENTAIRE  
certifying authority : AFAQ AFNOR  
CERTIFICATION. Adress:11, Avenue  
Francis de Pressense - 93571  
Saint-Denis La Plaine Cedex - France.  
Conformity with regulation NF031.  
Certified guarantees: fitness for cleaning,  
thermal performance.



**Electrolux**

330127

330252

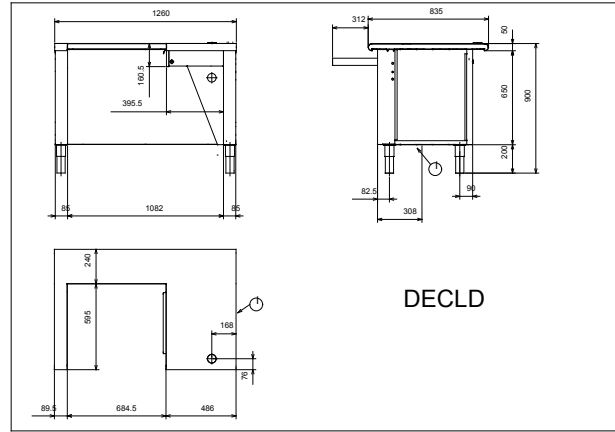
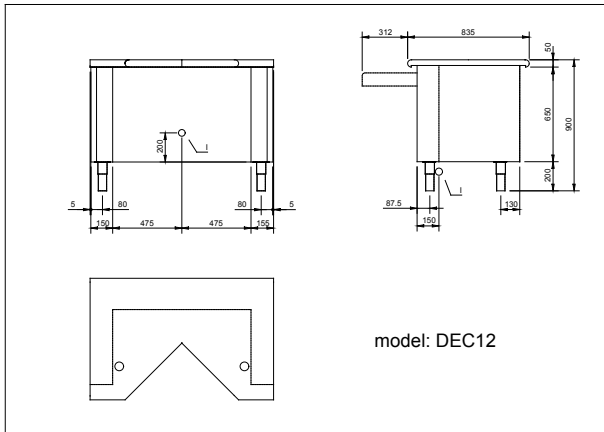

330253

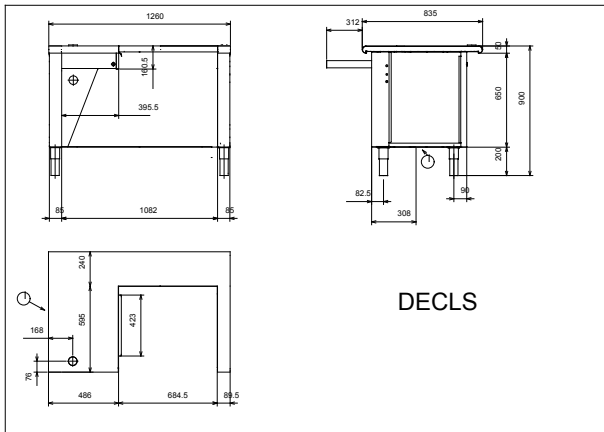

Electrolux Self Service

Cashier Units

FAI010

	ZLC12 330127	ZLCL12R 330252	ZLCL12L 330253
<b>TECHNICAL DATA</b>			
Neutral	●	●	●
External dimensions - mm			
width	1260	1260	1260
depth	835	835	835
height	900	900	900
Foot type	Round	Round	Round
Foot size	2"	Ø 56	Ø 56
Net weight - kg.	88	100	100
<b>ACCESSORIES</b>			
2 BEECH FINISH CURVED FRONT PANELS 400MM	856061	856061	856061
2 BEECH WOOD FINISH FRONT PANELS 400MM	856187	856187	856187
2 CHERRY WOOD FINISH FRONT PANELS 400MM	856410	856410	856410
2 END ELEM. F.CURVED BEECHW.FINISH PANEL	856067	856067	856067
2 END ELEM. F.CURVED CHERRY FINISH PANEL	856420	856420	856420
2CHERRY FINISH CURVED FRONT PANELS 400MM	856411	856411	856411
BEECH WOOD FINISH TRAY SLIDER (3 GN)	856029	856029	856029
CHERRY WOOD FINISH TRAY SLIDER (3GN)	856403	856403	856403
L/H END ELEM(CHERRY FINISH)+HOT PL.LOWER	856565		
L/H END ELEM.-CHERRY FINISH ROUND PANEL	856282	856282	856282
L/H END ELEM.STRAIGHT(CHERRY)+KICK.STRIP	856429	856429	856429
L/H END ELEMENT W.PLATE LOWER 25XD.255MM	856284	856284	856284
L/H END ELEMENT-S/S PANEL	856424	856424	856424
L/H END ELEMENT-S/S PANEL+KICK.STRIP	856422	856422	856422
R/H END ELEM(CHERRY FINISH)+HOT PL.LOWER	856564		
R/H END ELEM.-CHERRY FINISH ROUND PANEL	856281	856281	856281
R/H END ELEM.STRAIGHT(CHERRY)+KICK.STRIP	856428	856428	856428
R/H END ELEMENT W.PLATE LOWER.25XD.255MM	856283	856283	856283
R/H END ELEMENT-S/S PANEL+KICK.STRIP	856421	856421	856421
R/H END ELEMENT-SS PANEL	856423	856423	856423
R/H ROUND END EL.,PL.LOWER.NEUTR.FINISH	856489	856489	856489
ROUND END PLATE L/H.NEUTR.FINISH FRONTAG	856488	856488	856488
S/S FRONT KICKING STRIP (3 GN)	856073	856073	856073
S/S KICK.STRIP-INT.SIDE-CASHIER UNIT	856080		
S/S TUBULAR TRAY SLIDER (3 GN)	856039	856039	856039

2008-04-03

Subject to change without notice