

## Refrigerated platform lowerator

Electrolux offers a meals distribution and packaging system, ideal for hospitals and clinics, which provides the solution to the most complex and wide-ranging demands. The flexibility, capacity and efficiency of the MD System is derived from the broad range of equipment and accessories available to provide innumerable installation possibilities. The MD System guarantees the transport, conservation and distribution of food in perfect condition in terms of hygiene, temperature and safety. The model detailed on this sheet is a refrigerated platform lowerator trolley for plates and baskets.



344102

### Functionality

- Refrigerated platform lowerator trolley.
- Platform dimensions 550x550 mm. Self leveling and stabilizing mechanism. Fully free space on the platform, no drives are required.
- Stocking capacity:
  - 360 rectangular plates
  - 10 baskets 550X550X70H mm
  - 5 baskets 550X550X135H mm
- Ventilated refrigeration
- Digital temperature display and setting
- Removable insulated S/S lid with side hanging device
- Drainage 15 mm diam. in the bottom of the trolley
- Electrical cable with spiral, and safety locking antibreak
- 4 swivelling wheels 125 mm diam. 2 c/with break
- Ergonomic handle on the top of the trolley

- 4 rubber bumpers grey color
- Support for the electric cable
- HACCP available as conveyor belt option

### Reliability

- Structure in 40x40 S/S (AISI 304) squared tube, Scotch Brite finishing
- S/S (AISI 304) panels Scotch Brite finishing.
- S/S Top (AISI 304) Scotch Brite finishing
- Refrigeration unit hermetic type. Automatic defrosting water evaporation
- Air recirculation
- Thermal insulation with polyurethane foams HCFC and CFC free
- Refrigeration unit with hermetic compressor 0,33 kW. Refrigerant gas R404a
- Wheels with antistatic and antitrack technopolymer track

- Integrated bumpers.

### Cleanability

- Water resistance IPX5.
- Large smooth surfaces.

344102

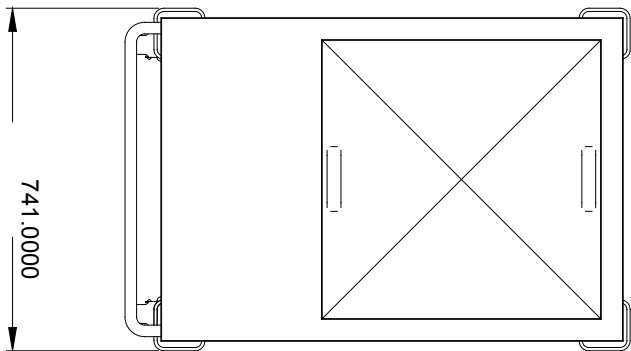
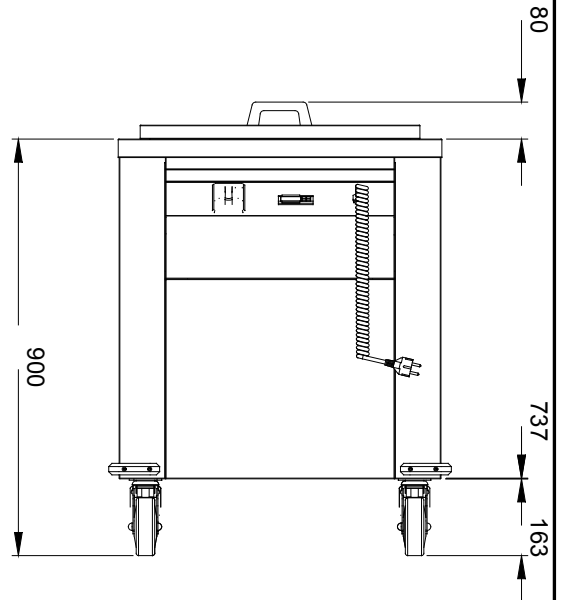
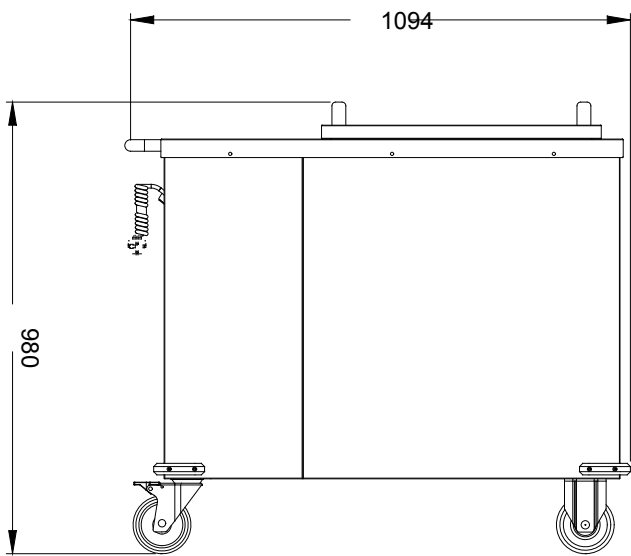

Electrolux MD System

Refrigerated platform lowerator

GBF010

2008-04-03

Subject to change without notice

	MDL0P10R 344102
<b>LEGEND</b>	
I - Electrical connection	230 V, 1N, 50
<b>TECHNICAL DATA</b>	
External dimensions - mm	
width	1094
depth	741
height	980
Cabinet	
temperature - °C	+2/+10
Power - kW	
installed-electric	0.33
Wheel	
material	Zinco
diameter	Ø 125
Net weight - kg.	95
Supply voltage	230 V, 1N, 50
<b>ACCESSORIES</b>	
S/S STACKABLE BASKET-550X550 X 135 MM	855611
S/S STACKABLE BASKET-550X550 X 70 MM	855610